

Electric Chain Hoist Model BC

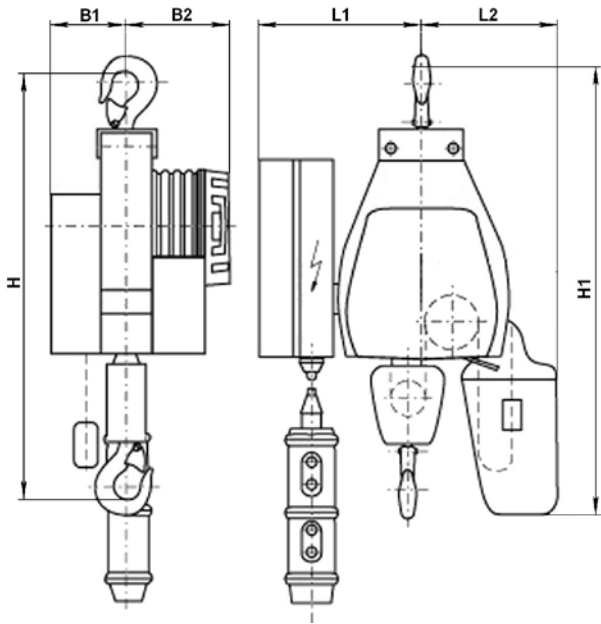

upper hook

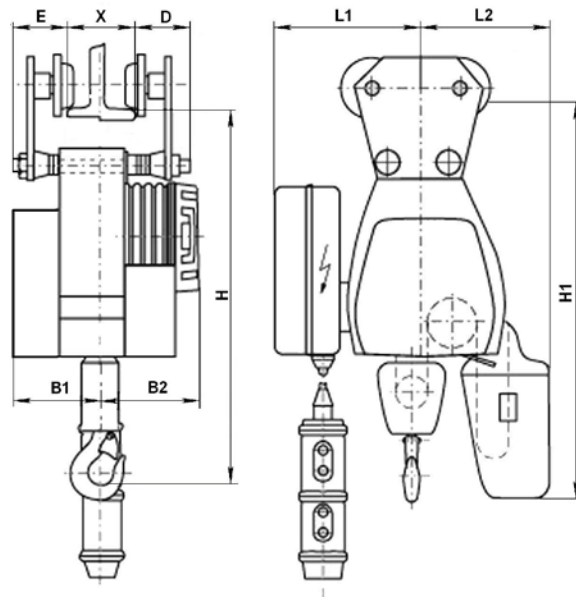

push trolley

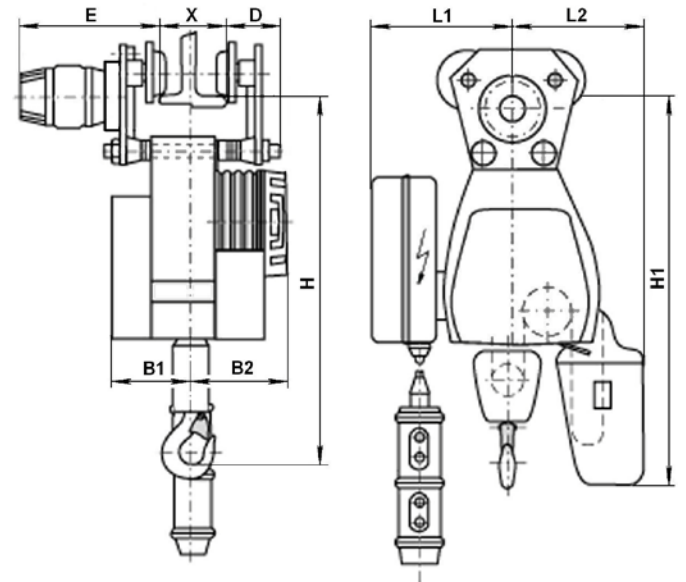

motorized trolley



Mizia Hoists Inc. 5151 Everest Drive Unit #4, Mississauga, ON, Canada L4W 2Z3
 Phone: (905) 238 6401 Fax: (905) 238 6943 Email: mizia_hoist@bellnet.ca www.miziahoist.com

Overall dimensions (mm)

MODEL	RATED LOAD	REEVING	H	H1	B1	B2	L1	L2	E	D
-	kg	-	mm	mm	mm	mm	mm	mm	mm	mm
BC033M	500	1/1	668	705	125	155	280	235	-	-
BC053M	500	1/1	600	635	125	155	280	235	90	90
BC093M	500	1/1	600	635	125	155	280	235	235	90
BC043M	1000	2/1	752	705	125	155	280	235	-	-
BC063M	1000	2/1	684	637	125	155	280	235	90	90
BC103M	1000	2/1	684	637	125	155	280	235	235	90

Overall dimensions (inch)

MODEL	RATED LOAD	REEVING	H	H1	B1	B2	L1	L2	E	D
-	lb	-	inch	inch	inch	inch	inch	inch	inch	inch
BC033M	1,100	1/1	26.30	27.76	4.92	6.10	11.02	9.25	-	-
BC053M	1,100	1/1	23.62	25	4.92	6.10	11.02	9.25	3.54	3.54
BC093M	1,100	1/1	23.62	25	4.92	6.10	11.02	9.25	9.25	3.54
BC043M	2,200	2/1	29.61	27.76	4.92	6.10	11.02	9.25	-	-
BC063M	2,200	2/1	26.93	25.08	4.92	6.10	11.02	9.25	3.54	3.54
BC103M	2,200	2/1	26.93	25.08	4.92	6.10	11.02	9.25	9.25	3.54

All dimensions are subject to change without notice. IF clearances are critical, ask for certified drawing.